

ALLELAC UV/LED NAIL LAMP 8809 CORDLESS

Model: 8809

Certificate No.: LCT-250401012189, LCT-250401012190, LCT-250401012194

Alle
LAC

DANE TECHNICZNE:

Power: 1.6W

Nominal input: 3.7V

Nominal output: 3.7V

Number of LEDs: 1 pc

Battery capacity: 200 mAh

Wavelength: 365-415 nm

1. SAFETY OF USE:

1. Do not immerse the lamp in water or use it in a damp environment.
2. Keep out of reach of children to prevent misuse or damage.
3. The product does not support charging during operation.
4. Ensure that the lamp light shines only on the nails to minimize direct skin exposure.

2. THE SET INCLUDES:

- 8809 lamp
- Stand
- USB-C cable
- User manual
- Warranty card

3. CHARACTERISTICS OF THE DEVICE:

1. Touch button
2. LED display
3. USB-C port
4. Lampa
5. Foldable stand

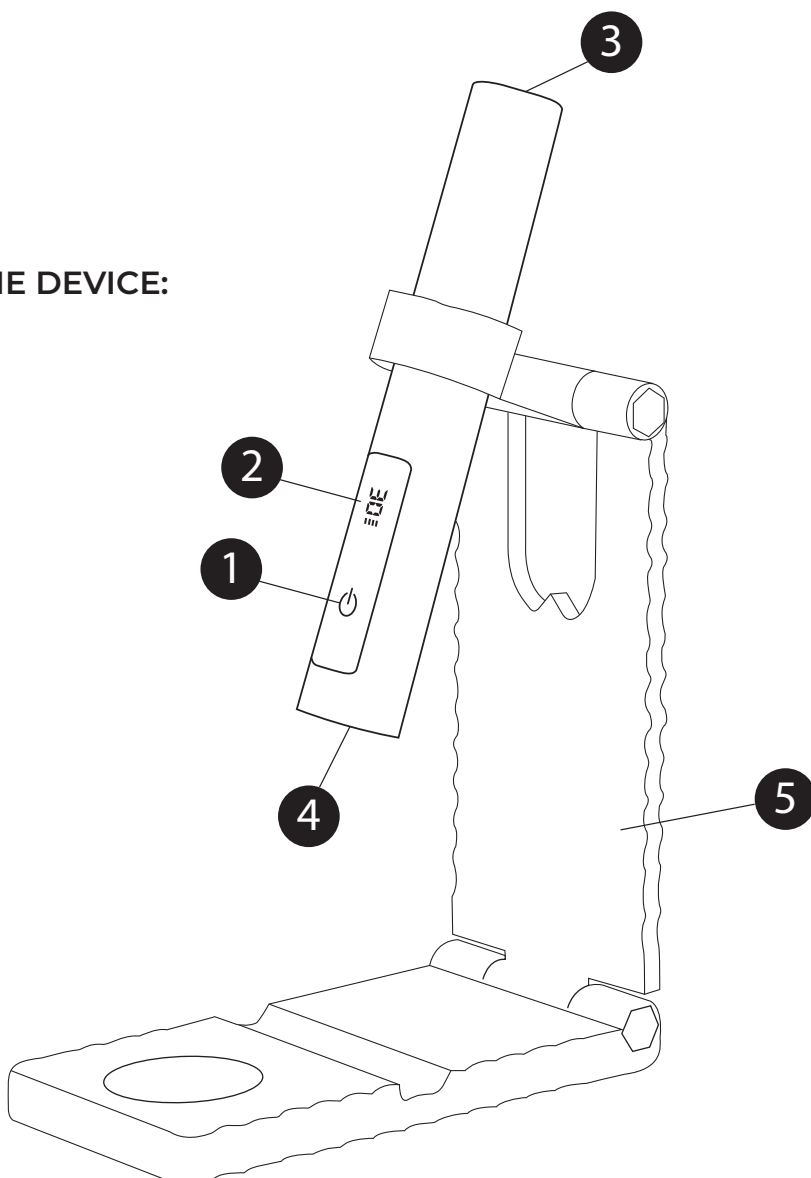

4. OPERATING INSTRUCTIONS:

1. **Power on:** Tap once to activate 30-second mode; press and hold longer to activate 60-second mode.
2. **Charging:** Connect to power via USB Type-C port; during charging, the digital display flashes, and when fully charged, it stays on continuously.

EFFICIENT LIGHT SOURCE:

1. High-quality diodes accurately illuminate the nail area, minimizing skin exposure and preventing skin damage.

RAPID CURING:

1. Curing the the gel polish within 8 seconds.
2. Curing the top coat within 12 seconds.



In accordance with art. 13 sec. 1 of the Act of 11 September 2015 on used electrical and electronic equipment (Journal of Laws 2015 item 1688), we inform you about the correct handling of waste electrical and electronic equipment:

1. It is prohibited to place used electrical and electronic equipment together with other waste - this is confirmed by the marking in the form of a "crossed-out bin", which requires selective collection of this type of waste.
2. Electrical and electronic devices may contain hazardous substances, mixtures and components, which, after entering the environment, may pose a serious threat to the health and life of humans and living organisms.
3. Used electrical and electronic equipment should be transferred only to authorized collection points, the list of which should be included on the website of each Municipal Office.
4. Households play a key role in the waste management system for used electrical and electronic equipment due to the possibility of their direct transfer to authorized collection points and the elimination of undesirable social habits resulting in leaving waste equipment in places not intended for this purpose.



In accordance with Directive 2006/66/EC of the European Parliament and of the Council of 6 September 2006 on batteries and accumulators and waste batteries and accumulators and repealing Directive 91/157/EEC, this product is marked with the symbol of a crossed-out wheeled bin. The symbol indicates that the batteries or accumulators used in this product should not be disposed of with normal household waste. Users of batteries and accumulators must use the available collection network for these items that enables their return, recycling and disposal.

IMPORTER
GNBLAB sp. z o.o.
ul. Piotrkowska 270
90-361 Łódź, Polska
www.gnb-lab.com
uwagi@gnb-lab.com

Produced for:
Allepaznokcie Michał Szewczyk
ul. Piotrkowska 270, Łódź
www.allepaznokcie.pl

Made in PRC